

Алматы (7273)495-231
Ангарск (3955)60-70-56
Архангельск (8182)63-90-72
Астрахань (8512)99-46-04
Барнаул (3852)73-04-60
Белгород (4722)40-23-64
Благовещенск (4162)22-76-07
Брянск (4832)59-03-52
Владивосток (423)249-28-31
Владикавказ (8672)28-90-48
Владимир (4922)49-43-18
Волгоград (844)278-03-48
Вологда (8172)26-41-59
Воронеж (473)204-51-73
Екатеринбург (343)384-55-89

Иваново (4932)77-34-06
Ижевск (3412)26-03-58
Иркутск (395)279-98-46
Казань (843)206-01-48
Калининград (4012)72-03-81
Калуга (4842)92-23-67
Кемерово (3842)65-04-62
Киров (8332)68-02-04
Коломна (4966)23-41-49
Кострома (4942)77-07-48
Краснодар (861)203-40-90
Красноярск (391)204-63-61
Курск (4712)77-13-04
Курган (3522)50-90-47
Липецк (4742)52-20-81

Магнитогорск (3519)55-03-13
Москва (495)268-04-70
Мурманск (8152)59-64-93
Набережные Челны (8552)20-53-41
Нижний Новгород (831)429-08-12
Новокузнецк (3843)20-46-81
Ноябрьск (3496)41-32-12
Новосибирск (383)227-86-73
Омск (3812)21-46-40
Орел (4862)44-53-42
Оренбург (3532)37-68-04
Пенза (8412)22-31-16
Петрозаводск (8142)55-98-37
Псков (8112)59-10-37

Пермь (342)205-81-47
Ростов-на-Дону (863)308-18-15
Рязань (4912)46-61-64
Самара (846)206-03-16
Саранск (8342)22-96-24
Санкт-Петербург (812)309-46-40
Саратов (845)249-38-78
Севастополь (8692)22-31-93
Симферополь (3652)67-13-56
Смоленск (4812)29-41-54
Сочи (862)225-72-31
Ставрополь (8652)20-65-13
Сургут (3462)77-98-35
Сыктывкар (8212)25-95-17
Тамбов (4752)50-40-97

Тверь (4822)63-31-35
Тольятти (8482)63-91-07
Томск (3822)98-41-53
Тула (4872)33-79-87
Тюмень (3452)66-21-18
Ульяновск (8422)24-23-59
Улан-Удэ (3012)59-97-51
Уфа (347)229-48-12
Хабаровск (4212)92-98-04
Чебоксары (8352)28-53-07
Челябинск (351)202-03-61
Череповец (8202)49-02-64
Чита (3022)38-34-83
Якутск (4112)23-90-97
Ярославль (4852)69-52-93

Россия +7(495)268-04-70

Казахстан +7(7172)727-132

Киргизия +996(312)96-26-47

www.elkos.nt-rt.ru | | eow@nt-rt.ru

Каталог продукции на устройства управления дизельными двигателями КОМПАНИИ **ELCOS**

CONTROL UNITS FOR ENGINE CONTROL AND PROTECTION



Starts, monitors and protects the diesel engine, stopping it in the event of an anomaly via solenoid valve or electromagnet. Shows the main parameters of the diesel engine on the display.

Instruments

- tachometer
- total hour meter
- fuel level indicator
- battery voltmeter

Features

- Installation on board and in open air
- Automatic faults surveillance with messages on the display
- Texts in 6 languages: Italian, English, French, German, Spanish and Portuguese
- Preheating glow plugs management

FASTENING

with two or three brackets

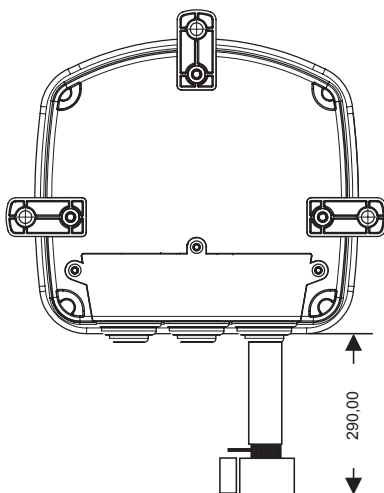

DIMENSIONS

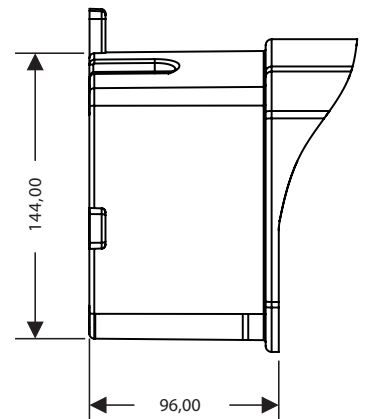
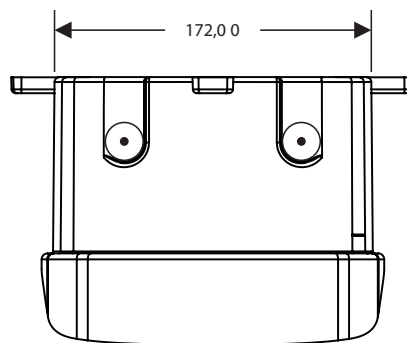

CONTROL UNITS FOR ENGINE CONTROL AND PROTECTION

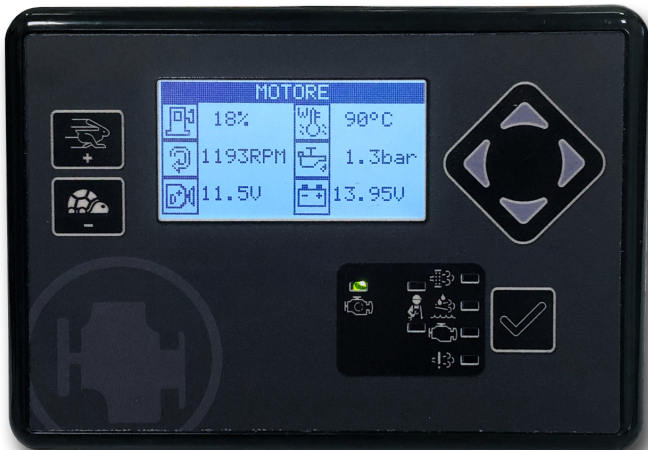

DIP-337

The DIP-337 allows you to start and stop the diesel engine using an externally connected ignition key.

While the engine is running, it performs a complete control, displaying instruments and alarms on its backlit 128 x 64 dot graphic display.

Through the front keys it can also control a linear actuator with which vary the rpm of the diesel engine.

It can work with engines equipped with ECU engine control unit with CAN Bus serial line with SAE J1939 protocol.

The messages shown on the display allow an easy management of the functions. Pop-ups appear that explicitly indicate the current running status and display in text mode all the anomalies that have occurred or possible warning that could lead the engine to stop.

CEP-337 is the dashboard where the DIP-337 control is installed with the addition of the ignition key. The DIP-337 has a graphic display that allows you to view more instruments and to access the programming from its front panel.

The display shows the following instruments:

- Fuel level in the tank [%]
- Engine tachometer [RPM]
- Motor temperature expressed in [°C] or in [°F] (as factory setting this instrument is excluded)
- Engine oil pressure expressed in [bar] or in [kPa] or in [psi] (as factory setting this instrument is excluded)
- Battery voltage [V]
- D+ voltage (pre-excitation alternator) [V]
- Total hour counter [hh: mm]
- Partial hour counter [hh: mm]
- Conta avviamenti [n]
- Scadenza delle manutenzioni
- Calendar clock

Alarms are always shown on the display, also the STOP ANOMALY LED lights up if the engine is stopped, while the SIGNAL WARNING LED lights up if the anomaly is just a pre-alarm.



CEP-337

DIMENSIONS

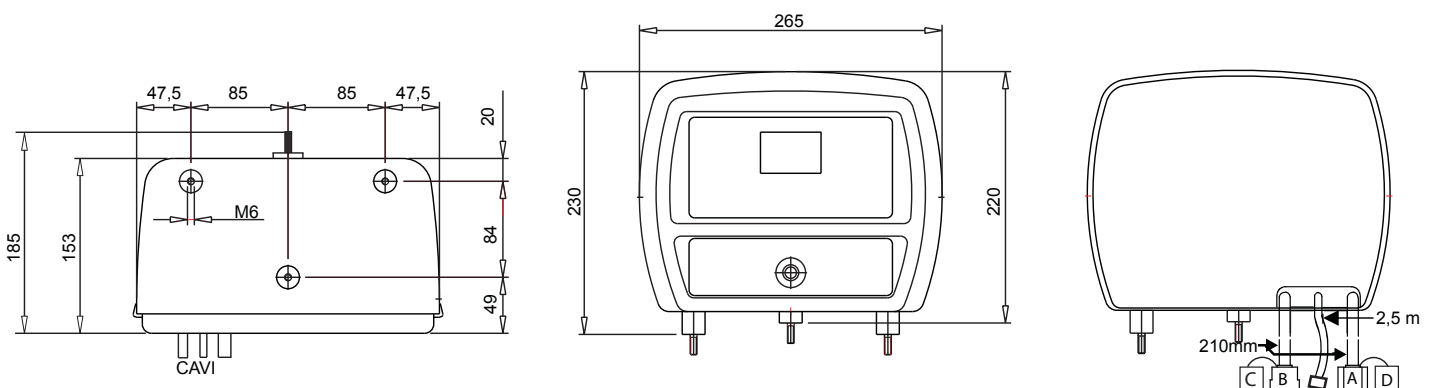

DCA-339

AUTOMATIC CONTROL UNITS FOR DIESEL ENGINES



DCA-339

- Complete automatic control from remote contact (with possible float filling/emptying programs).
- Graphic display complete with all digital instruments with various possible views.
- StageV diesel engine ready CAN Bus SAE J1939 (with regeneration control, etc.).
- RS-232, RS-485 serial ports and USB 2.0.
- Possibility to connect with GSM modem or GTW-4.0 gateway.
- Fully programmable inputs and outputs.
- Possibility to connect actuator with acceleration/deceleration command, both manual and automatic.
- Texts in 6 languages + 1 programmable.
- Fully programmable with ZW-SMART software.

NF-1300

AUTOMATIC CONTROL PANELS FOR DIESEL ENGINES



NF-1300 with DCA-339

AUTOMATIC CONTROL UNITS FOR DIESEL ENGINES



DCA-109

- Complete automatic control by remote contact.
- Digital instruments.
- Texts in 6 languages.
- Internal clock to program start / stop within 24 hours.
- Weekly test.
- Programmable start if the battery is low on charge.

AUTOMATIC CONTROL PANELS FOR DIESEL ENGINES



NF-1100 with DCA-109

GATEWAY GTW 4.0

The GATEWAY GTW-4.0 is used to remotely manage the diesel engine. It is possible to connect up to 5 control units with a single GTW-4.0 in order to remotely monitor the system, it is an IOT system.

NEW

CLOUD SERVER

Connected via WiFi, Ethernet port or 4G-LTE modem.



The gateway is programmable via PC, once connected via Bluetooth, USB or RS-232 locally or via the Cloud.

Once installed, the device provides:

- Geolocation and position-based identification.
- Multiple levels of access, with hierarchical differentiation, using customisable credentials and logos.
- Access from any device.
- Possibility to reach and manage multiple systems.
- Possibility to communicate with each Elcos device present on the individual systems, managing them separately.

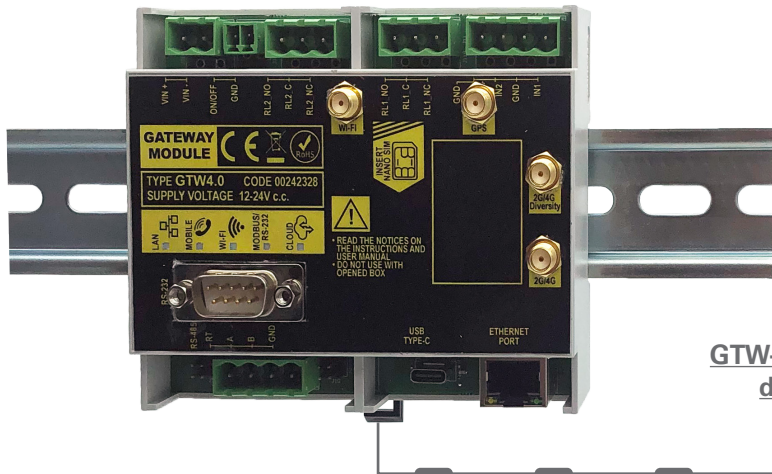
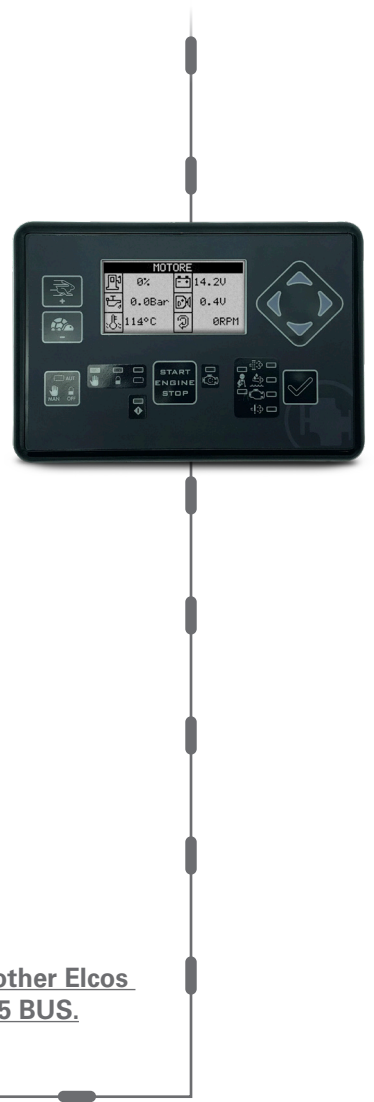

GTW-4.0 communicates with other Elcos devices via isolated RS-485 BUS.

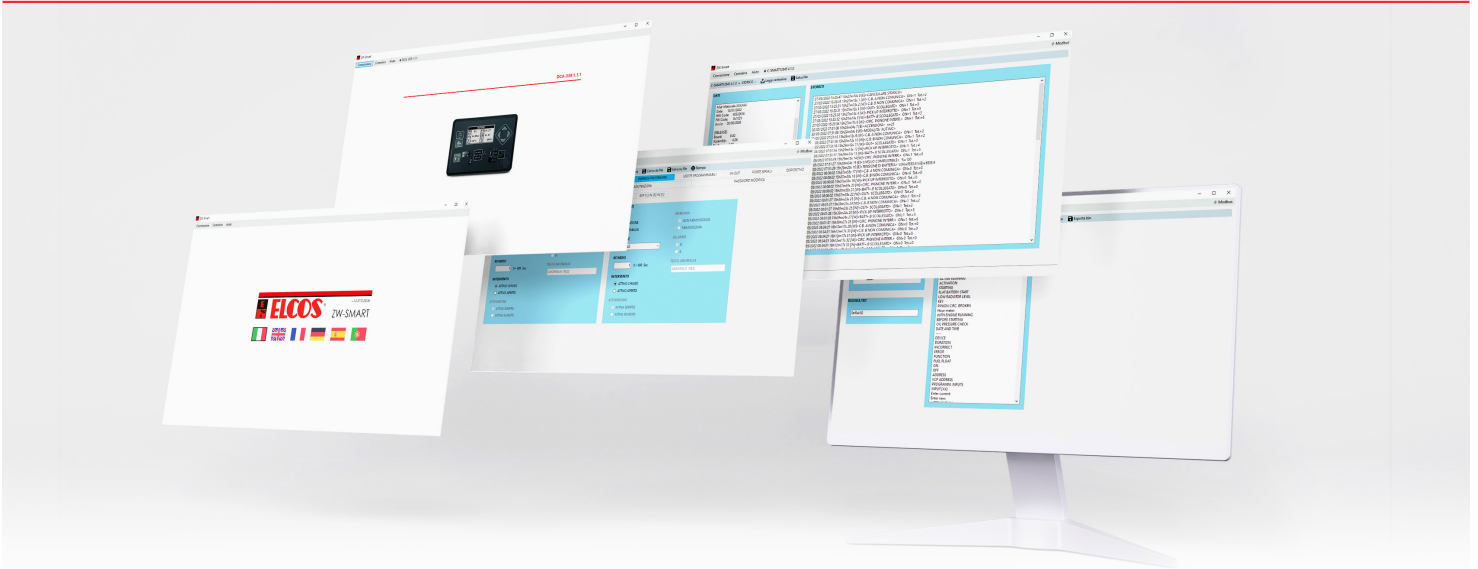

Software developed for set-up of the control unit via USB port.

Once connected to the PC, the latter will automatically recognise the control unit and make it possible to:

- Consult settings more easily.
- Upload factory settings.
- Upload or download dedicated settings.
- Upload or download custom logos.
- Add a custom language.

CBS and CBA

AUTOMATIC BATTERY CHARGERS FOR LEAD ACID BATTERIES



Fitted with hook for DIN bar.
With three charging levels: fast charge with current control, intermediate, and maintenance.

**CBS-031 (3.5A)
CBS-061 (6A)**

RS-485 serial communication port from which they transmit battery voltmeter, charging current ammeter and battery status.

Signals due to short circuiting, polarity inversion, and battery cable disconnection.



CBS-010 (1A)

Simple battery charge status signal LED.

CBA-030 (3A) CBA-060 (6A)

- With mains decoupling transformer
- Quick charge with current control
- Intermediate and maintenance charge with voltage control
- Possibility of remote reporting
- Self-protection with cumulative reporting in case of:
 - short circuit
 - polarity inversion
 - insufficient battery voltage

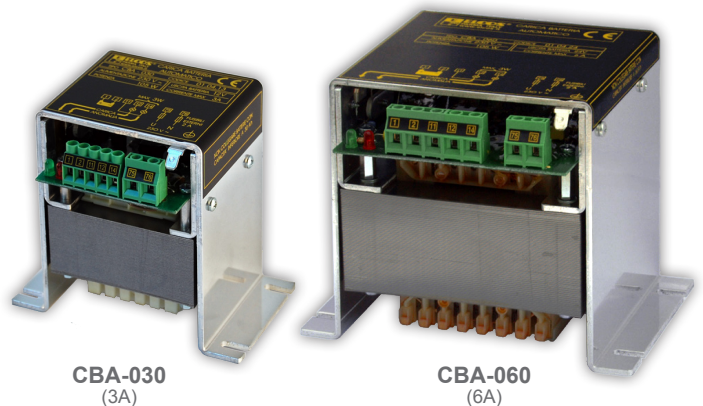

DEVICES FOR ENGINE PROTECTIONS

Start-up with externally installed key

These devices are made in containers of reduced size and completely incorporated with polyurethane resin.

Frontal protection degree
IP66

Rear (connections)
IP00



DEVELOPED TO PROTECT

engines, stopping them in case of anomaly due to:

	DIP-806	DIP-804	DIP-521
Insufficient oil pressure	X	X	X
Overtemperature	X	X	X
Inefficient battery charging alternator (belt breakage)	X	X	X
Fuel reserve (does not stop the engine)	X	X	
Low coolant level	X		
Overfrequency	X		

SPEED DETECTION DEVICES



Via magnetic transducer

MOS - 100/00

Detects the running engine, simulates terminals W and D+ of a battery charge alternator

DRV - 100

Detects overspeed of a diesel engine

Via battery charge alternator

DRS - 100

Detects overspeed of a diesel engine

RADIATOR LEVEL PROBE

Indicates insufficient coolant level in the radiator



For expansion tank made of:

PLASTIC: SOL-010/00

METAL: SOL-015/00

HEATERS TO BE INSERTED IN THE COOLING WATER CIRCUIT OF THE DIESEL ENGINE

- 230Vac or 110Vac power supply (RA-0511/110 and RA-1011/110 only).
- Heaters equipped with internal operating thermostat.
- Equipped with coolant discharge plug.
- Protective electrophoretic coating.
- IP54 protection degree.
- 3 meter connection cable.

Versions with GAS ½" thread

Tipo

RA-0511 (500W)

RA-1011 (1000W)

RA-0511/110 (500W)

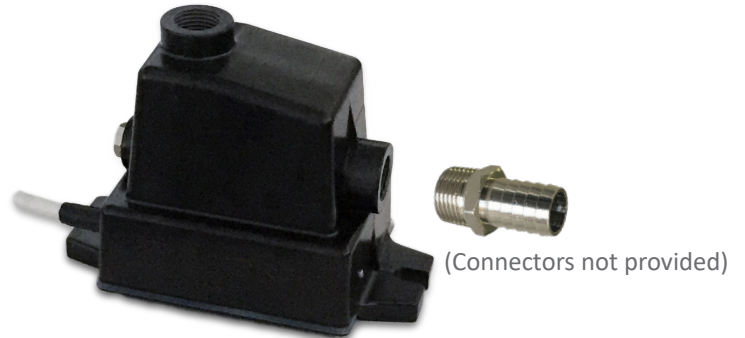

Version with hose connectors for ø 16 internal hose

Type

RA-0500 (500W)

RA-1000 (1000W)

RA-1500 (1500W)

Coolant drainage plug cooling



Versions with GAS ½" thread

Type

RA-0501 (500W)

RA-1001 (1000W)

RA-1501 (1500W)

RA-2501 (2500W)

RA-1011/110 (1000W)



OIL HEATERS FOR DIESEL ENGINES

FOR APPLICATIONS IN CONTACT WITH THE SUMP

- 230Vac power supply.
- Heaters equipped with internal operating thermostat.
- IP54 protection degree.
- 3 meter connection cable.



RO-405
(350W)

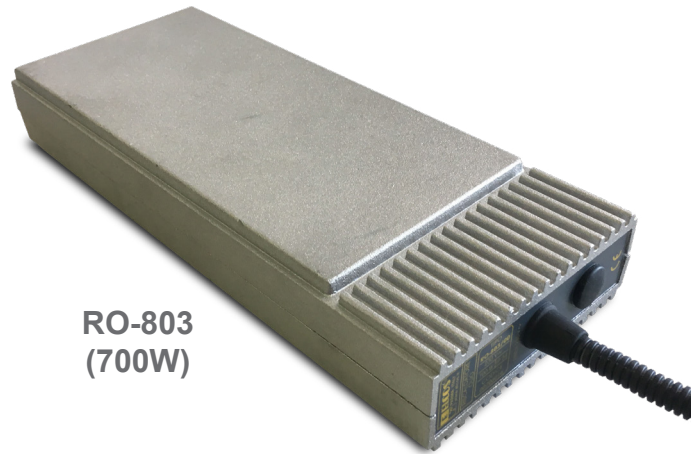

RO-803
(700W)

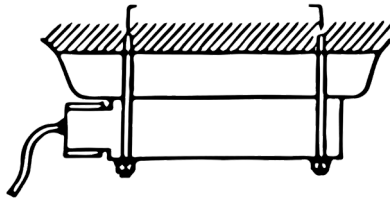
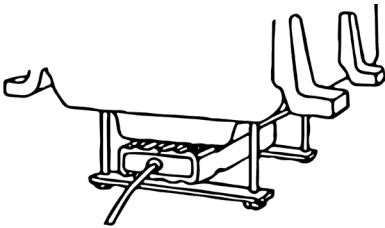

SPEED TRANSDUCERS

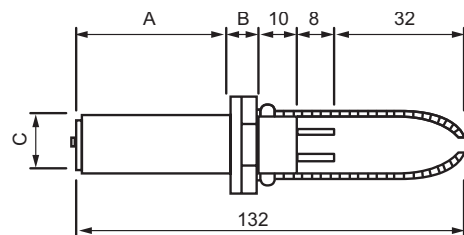

PICK-UP
M16x1.5
M18x1.5
5/8"-W18-UNF
3/4"-W16-UNF

TYPE	A	B	C
TM90-M16	68	8	M16x1.5
TM90-M18	66	9	M18x1.5
TM90-5/8	67	8	5/8"W18-UNF
TM90-3/4	66	9	3/4"W16-UNF

TRACTION ELECTROMAGNETS FOR STOPPING DIESEL ENGINES

INTERMITTENT SERVICE



ESI-060/00

TYPE	STROKE mm	FORCE KG	
		At stroke start	At stroke end
ESI-046/00	35	1	25
ESI-060/00	50	5	50

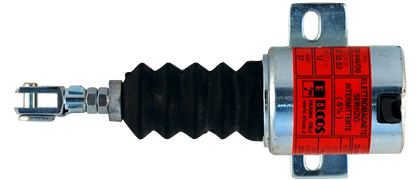

ESI-046/00

CONTINUOUS SERVICE



ESC-060/00

TYPE	STROKE mm	FORCE KG	
		At stroke start	At stroke end
ESC-046/00	35	3	12
ESC-060/00	50	7,5	30

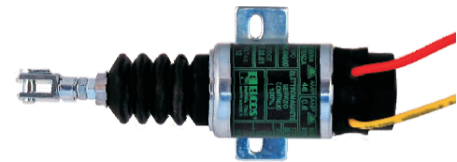

ESC-046/00

VAR

LINEAR ACTUATORS

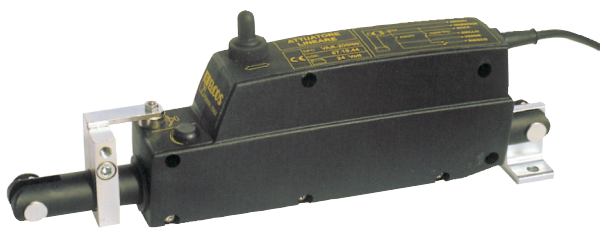

VAR-201

Force 30Kg



VAR-150/00

- Remote and front control
- Stroke 60mm (**adjustable**)

- Stroke 70mm (**not adjustable**)

Алматы (7273)495-231
Ангарск (3955)60-70-56
Архангельск (8182)63-90-72
Астрахань (8512)99-46-04
Барнаул (3852)73-04-60
Белгород (4722)40-23-64
Благовещенск (4162)22-76-07
Брянск (4832)59-03-52
Владивосток (423)249-28-31
Владикавказ (8672)28-90-48
Владимир (4922)49-43-18
Волгоград (844)278-03-48
Вологда (8172)26-41-59
Воронеж (473)204-51-73
Екатеринбург (343)384-55-89

Иваново (4932)77-34-06
Ижевск (3412)26-03-58
Иркутск (395)279-98-46
Казань (843)206-01-48
Калининград (4012)72-03-81
Калуга (4842)92-23-67
Кемерово (3842)65-04-62
Киров (8332)68-02-04
Коломна (4966)23-41-49
Кострома (4942)77-07-48
Краснодар (861)203-40-90
Красноярск (391)204-63-61
Курск (4712)77-13-04
Курган (3522)50-90-47
Липецк (4742)52-20-81

Магнитогорск (3519)55-03-13
Москва (495)268-04-70
Мурманск (8152)59-64-93
Набережные Челны (8552)20-53-41
Нижний Новгород (831)429-08-12
Новокузнецк (3843)20-46-81
Ноябрьск (3496)41-32-12
Новосибирск (383)227-86-73
Омск (3812)21-46-40
Орел (4862)44-53-42
Оренбург (3532)37-68-04
Пенза (8412)22-31-16
Петрозаводск (8142)55-98-37
Псков (8112)59-10-37

Пермь (342)205-81-47
Ростов-на-Дону (863)308-18-15
Рязань (4912)46-61-64
Самара (846)206-03-16
Саранск (8342)22-96-24
Санкт-Петербург (812)309-46-40
Саратов (845)249-38-78
Севастополь (8692)22-31-93
Симферополь (3652)67-13-56
Смоленск (4812)29-41-54
Сочи (862)225-72-31
Ставрополь (8652)20-65-13
Сургут (3462)77-98-35
Сыктывкар (8212)25-95-17
Тамбов (4752)50-40-97

Тверь (4822)63-31-35
Тольятти (8482)63-91-07
Томск (3822)98-41-53
Тула (4872)33-79-87
Тюмень (3452)66-21-18
Ульяновск (8422)24-23-59
Улан-Удэ (3012)59-97-51
Уфа (347)229-48-12
Хабаровск (4212)92-98-04
Чебоксары (8352)28-53-07
Челябинск (351)202-03-61
Череповец (8202)49-02-64
Чита (3022)38-34-83
Якутск (4112)23-90-97
Ярославль (4852)69-52-93

Россия +7(495)268-04-70

Казахстан +7(7172)727-132

Киргизия +996(312)96-26-47

www.elkos.nt-rt.ru | | eow@nt-rt.ru